

Bulkfeeders

With AAE bulkfeeders, almost any kind of product can be fed in the desired quantity and at the desired rate. AAE develops, manufactures and supplies a specialized range of bulkfeeders, giving you the following advantages:

- Available in 4 standard sizes. (internal volume).
- The feeding belt can be made from various materials, depending on the application and the specific properties of the products that need to be handled. (e.g. FDA food grade material for the application in the food- and beverage industry).
- Steel undercarriage enabling a tilt angle of the conveyer belt in steps of 10° (tilt angle towards the horizontal plane is adjustable from 0° to 60°). The frame itself is coated in a RAL color to customer specifications, and can be fitted with swiveling rollers upon request.
- The position of the undercarriage to the conveying belt is adjustable. Combined with the adjustable tilt angle this enables almost any unloading position.
- Stainless steel upper part (body work). This eliminates the risk of contamination through paint-abrasion. The outside of the upper part is standard in plain SS, but can be painted in any RAL color upon request.
- The upper part is equipped with a hinged lid from impact-resistant polycarbonate. This protects the parts in the feeder from contamination.
- High torque motor drive.
- A connection cabinet is mounted to the undercarriage, fitted with a standard connector. This can be used as an interface to a machine control system or to a vibration feeder.
- As an extra option, the AAE bulkfeeders can be fitted with sensors upon request.
- The AAE bulkfeeders are supplied with a manual in the English language and comply with CE regulations.

The AAE bulkfeeders form a perfect combination with other products from our line of feeding- and handling equipment. Combined with for instance the AAE vibration feeders they form a reliable transportation system for your product handling. Picture 2 shows you a typical combination.

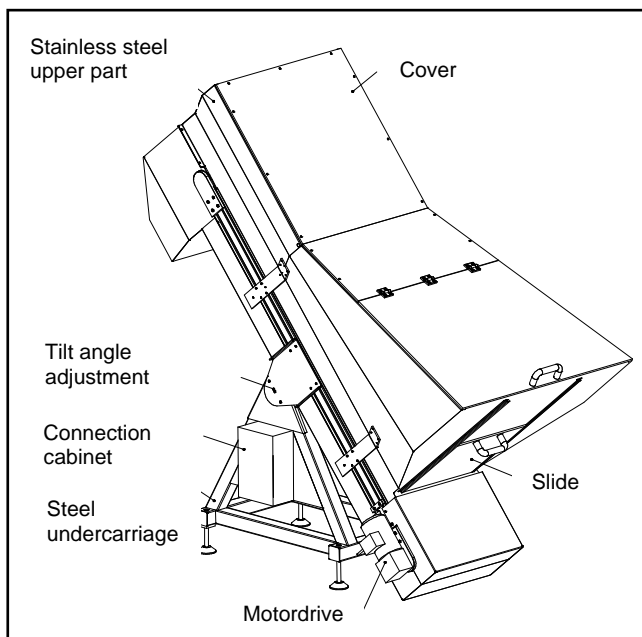
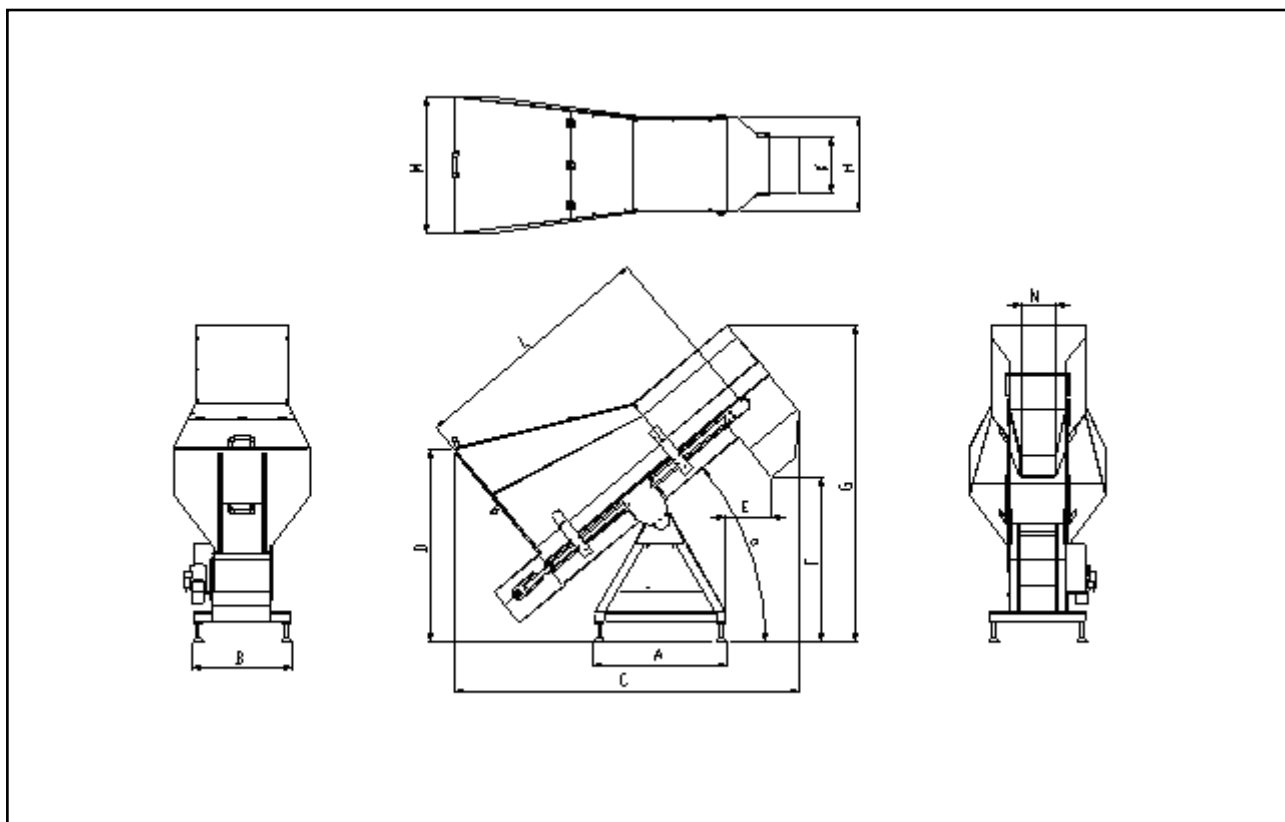

Figure 1 : main parts of the AAE bulkfeeders



Figure 2 : AAE bulkfeeder in combination with an AAE vibration feeder

Technical data



Picture 3 : main dimensions of the bulkfeeders (see tables below)

The tables below show the main dimensions of the bulkfeeders. The given outer dimensions are for a position with $\alpha = 40^\circ$. The internal volume is depending on the tilt angle towards the horizontal plane (angle α). The given volumes are the minimum volume at $\alpha=20^\circ$ and the maximum value at $\alpha=50^\circ$.

Model	Volume (liter) $\alpha=20^\circ$ $\alpha=50^\circ$	A x B (mm.)	C (mm.)	D (mm.)	E (mm.)	F (mm.)	G (mm.)
BF 50	127 39	820 x 626	1912	890	300	992	1758
BF 100	234 72	820 x 626	1941	890	300	992	1758
BF 250	590 190	820 x 626	2147	1222	280	1030	2000
BF 350	754 241	820 x 626	2147	1222	280	1030	2000

Model	H (mm.)	K (mm.)	L (mm.)	M (mm.)	Beltwidth (mm.)	N (mm.)	Weight ⁽¹⁾ (kg.)
BF 50	387	254	1559	1559	250	254	160
BF 100	587	454	1559	1559	450	454	210
BF 250	587	354	1559	1559	350	215	350
BF 350	737	504	1559	1559	500	391	500